

hvacel

*Dust Collection
System*



DUST COLLECTION SYSTEM

Jet-Pulse system automatically removes the dusts. The Jet-Pulse Bag Filter Units are specially designed for demanding filtration conditions. All cabin body, chassis and carrier legs are produced with proper sheet thickness with bolt nut connectors. High efficient automatic cleaning system reduces compressed air consumption and increases filter life.

Usage Areas

It is suitable for dust and chip collection systems of workshops such as workshops, factories, carpenter workshops.

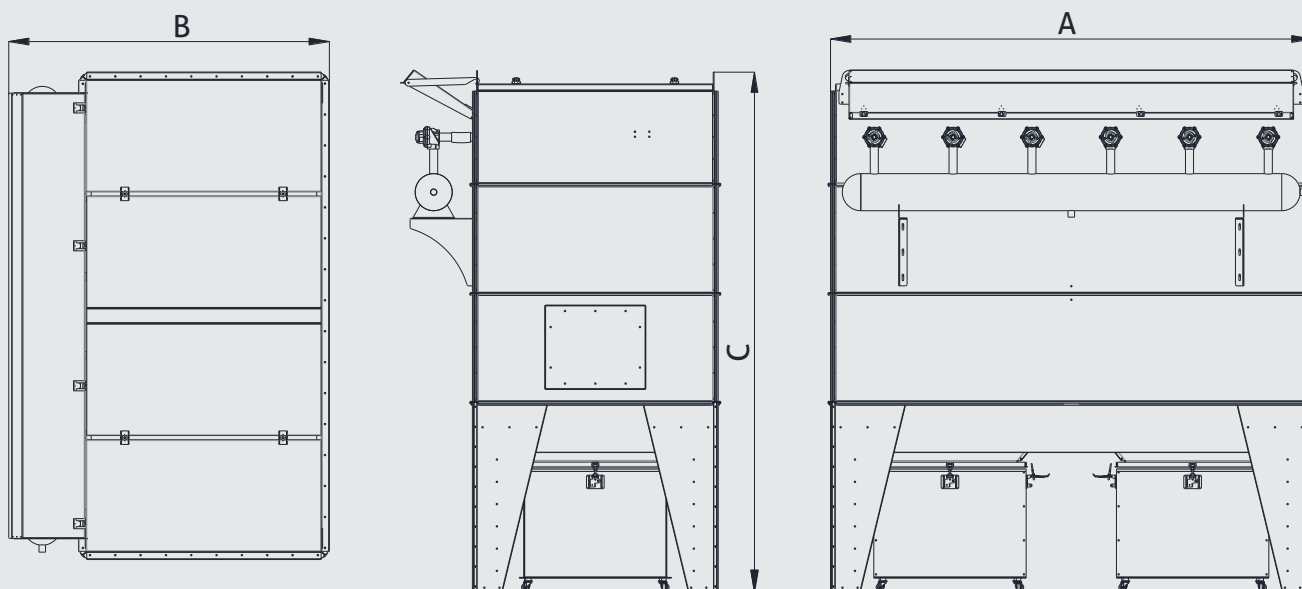

	A	B	C	TOTAL FILTER VOLUME	BUCKET VOLUME
MODEL	mm	mm	mm	m ²	m ³ x pcs.
TT-10.000	1490	1900	3050	252	0,46 x 1
TT-20.000	2890	1900	3050	380	0,46 x 2

hvacel



Contact Information:

*Address: Minareliçavuş OSB Mah. 202. Sk. N:19 Nilüfer /
BURSA / TURKEY*

Export & International Operations Manager:

Mr. Aslan TEKİN

Mobile: +90 552 616 40 57 (WhatsApp, Viber, Telegram)

Group Mail: export@hvacel.com

